

Pressure Reducing 3190 MPET

Pilot Operated Pressure / Temperature Regulating

SF International reserves the right to change the designs and/or materials of its products without notice, ©2013 SF International



3190-MPET is a pilot operated pressure reducing and temperature control valve, eliminating the need for separate pressure and temperature valves. It can be supplied with screwed connections BSPT (BS 21) or NPT (ANSI-B1.20.1). Flanges according to ANSI-B16.5 and ANSI-B16.1 class. Contact factory for other connection options.



FEATURES

Model	3190 MPET	
Sizes	1/2" - 2"	2 1/2" - 4"
Connections	Screwed	Flanged
Application	Steam, Water, Gases	
Body Material	GGG 40.3 Ductile Iron 216 WCB Carbon Steel	
Option	Reduced Port Trim	
PMO Max. Oper. Pressure	Ductile Iron	250 psig
TMO Max. Oper. Temperature	Ductile Iron	450°F
PMO Max. Oper. Pressure	Carbon Steel	293 psig
TMO Max. Oper. Temperature	Carbon Steel	600°F

DOWNSTREAM PRESSURE RANGES

Type A (Yellow): 3 to 28 psig

Type B (Blue): 14 to 100 psig

Type C (Gray): 77 to 200 psig

TECHNICAL DATA OF SOLENOID

Voltages available:	110/120 Vac or 220/240 Vac
Frequency:	50/60 Hz
Power Consumption:	45 VA
Types:	Normally Closed Normally Open

HOW TO ORDER

Specify:

- Model
- Sizes and type of connection

Example: 1 SF International 3110 MPE Valve with 1 1/2" body and BSPT connections and Type B pilot.

DIMENSIONS & WEIGHT (INCHES & POUNDS)

DN	A	B Screw	ANSI B16.1		ANSI B16.5		C	Weight
			125#	250#	150#	300#		
1/2"	6.30	5.51	-	-	-	-	19.49	33.73
3/4"	6.30	5.51	-	-	-	-	19.49	33.73
1"	7.28	5.94	-	-	-	-	19.69	41.89
1 1/4"	7.28	7.28	-	-	-	-	20.47	46.30
1 1/2"	7.28	7.28	-	-	-	-	20.47	46.30
2"	8.07	8.50	-	-	-	-	22.83	70.55
2 1/2"	14.25	-	10.79	11.10	10.79	11.10	28.74	157.63
3"	14.65	-	11.22	11.22	11.22	11.22	28.74	189.60
4"	16.34	-	14.53	14.53	14.57	14.57	31.89	260.15

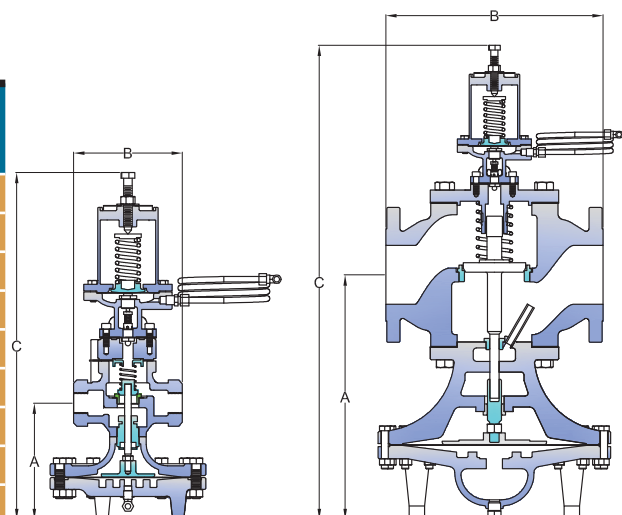

REGULATING



Pressure Reducing 3190 MPET

Pilot Operated Pressure / Temperature Regulating

REPAIRS AND MATERIALS

Pos.	Description	Material
1	Pilot Adjustment Spring Guide	AISI 420 SS
2	Pilot Diaphragm	AISI 301 SS
3	Pilot Seat	AISI 420 SS
4	Main Valve Spring Guide	AISI 420 SS
5	Screen	AISI 420 SS
6	Seat Head	AISI 420 SS
7	Stem	AISI 304 SS
8	Seat	AISI 420 SS
9	Coupling	AISI 420 SS
10	Coupling Gasket	Non Asbestos
11	Diaphragm	AISI 301 SS
12	Sensing Pipe	AISI 420 SS
13	Main Valve Spring	Spring Steel
14	Seat Gasket	Non Asbestos
15	Stem Lock-nut	AISI 304 SS
16	Cover Gasket	Non Asbestos
17	Body Gasket	Non Asbestos
18	Pilot Adjustment Spring	AISI 420 SS
19	Stem Guide	AISI 304 SS
20	Screen Ring	AISI 420 SS
21	Pilot Gasket	Non Asbestos
22	Lower Stem Guide	AISI 420 SS
23	Solenoid Valve	

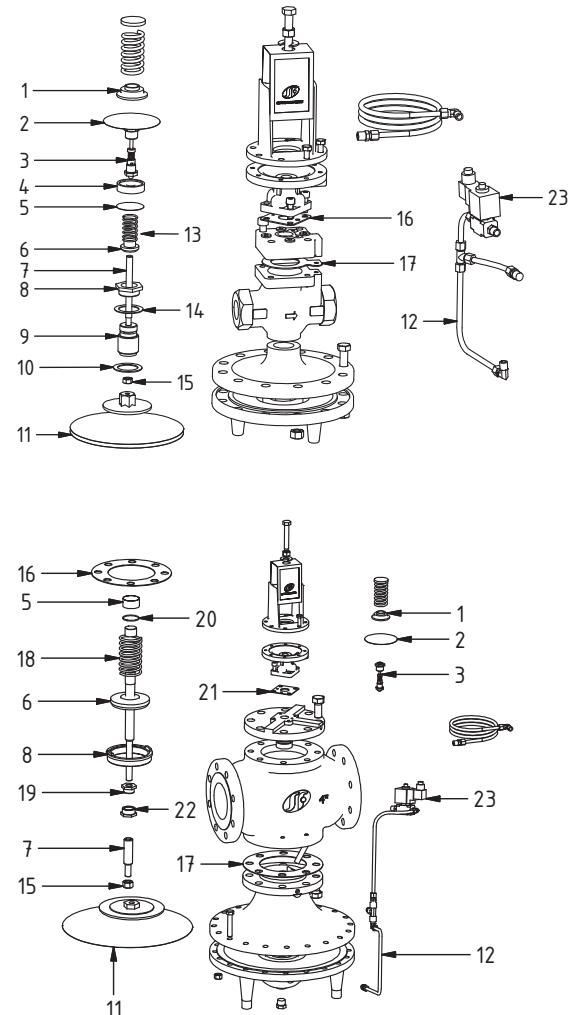

HOW TO ORDER SPARE PARTS (CODE)

Model	Description	Pos.	1/2"	3/4"	1"	1 1/4"	1 1/2"	2"	2 1/2"	3"	4"
3190 MPET	Pilot Diaphragm Assy	2	14,282	14,282	14,282	14,282	14,282	14,282	14,282	14,282	14,282
	Pilot MP-10 Seat Assy	3	6,358	6,358	6,358	6,358	6,358	6,358	6,358	6,358	6,358
	Pilot Gasket	16	10,927	10,927	10,927	10,927	10,927	10,927	10,927	10,927	10,927
	Stem	7	6,428	6,428	6,430	6,432	6,432	6,433	12,563	11,970	11,122
	Diaphragm Assy	11	15,181	15,181	14,315	14,315	14,315	15,182	8,773	8,773	15,180
	Gasket	14	6,434	6,434	6,436	6,438	6,438	6,439	11,031	12,574	11,038
	Sensing Pipe	12	6,458	6,458	6,460	6,462	6,462	6,463	11,366	12,611	9,698
	Seat Assy	8	6,422	6,423	6,424	6,425	6,426	6,427	12,432	11,874	11,123
	220V Solenoid Valve	-	6,484	6,484	6,484	6,484	6,484	6,484	6,484	6,484	6,484

REGULATING

INSTALLATION INSTRUCTIONS

This valve should be installed in a horizontal pipeline with the direction of flow as indicated by the arrow on the valve body.

SAFETY, INSTALLATION AND MAINTENANCE

For safety, installation and maintenance information see instructions supplied with the product (MI-0810-15).